

Traveling wave solutions for the space-time fractional (2+1)-dimensional Calogero-Bogoyavlenskii-Schiff equation via two different methods

Fares Bekhouche, Iryna Komashynska

Department of Mathematics
Faculty of Science
The University of Jordan
Amman 11942, Jordan

email: bekhouchefares73@gmail.com, i.kom@ju.edu.jo

(Received April 19, 2021, Accepted June 2, 2021)

Abstract

In this paper, we investigate the unified method and the modified Kudryashov method for obtaining exact traveling wave solutions of conformable fractional partial differential equations. In addition, a connection is given between the two methods. Then, using these methods, we obtain new exact solutions for the space-time fractional (2 + 1)-dimensional Calogero-Bogoyavlenskii-Schiff equation. Fractional derivatives are described in conformable sense. Various solutions have been obtained, including one-soliton, kink, anti-kink, periodic wave solutions, and multiple-soliton solutions. We also provide a graphical representation of some interesting exact solutions to the equation and discuss the behavior of these solutions. The considered methods can be effectively applied to a wide range of nonlinear fractional partial differential equations.

Key words and phrases: The unified method, the modified Kudryashov method, fractional partial differential equation, conformable derivative, traveling wave solution, the space-time fractional (2+1)-dimensional Calogero-Bogoyavlenskii-Schiff (CBS) equation.

AMS (MOS) Subject Classifications: 35R11, 35C07, 35C08.

Corresponding author email: i.kom@ju.edu.jo

ISSN 1814-0432, 2021, <http://ijmcs.future-in-tech.net>

1 Introduction

The use of nonlinear fractional partial differential equations (NFPDEs) in recent years has become increasingly important in modeling complex real-world phenomena in various fields of science and technology. Therefore, finding exact solutions to these equations has become the subject of interest for researchers. A lot of effective methods have been developed and used to obtain exact traveling solutions to NFPDEs. Some of these methods are the (G'/G) -expansion methods [1, 2], the Kudryashov method [3], the modified Kudryashov method [4, 5], the exp-function method [6], the Khater method [7], the first integral method [8], the extended tanh method [9, 10] and many others.

This work aims to develop two different approaches to solving NFPDEs, where the fractional derivative is defined in the sense of the conformable fractional derivative. These are the unified method [11, 12, 13, 14] and the modified Kudryashov method. We study and compare these two methods and also establish the connection between them. Besides, we apply the presented methods to find exact traveling wave solutions of the Calogero-Bogoyavlenskii-Schiff (CBS) equation. This equation was first obtained by Bogoyavlenskii and Schiff by two different ways. Bogoyavlenskii used the modified Lax formalism [15] and Schiff derived the equation by reducing the self-dual Yang-Mills equation [16]. The CBS equation describes the (2+1) dimensional interactions of long wave propagations and has diverse applications in physics, mathematics and engineering.

We consider the space-time fractional (2+1)-dimensional CBS equation as follows:

$$\mathfrak{I}_x^\beta \mathfrak{I}_t^\alpha u + \mathfrak{I}_x^\beta \mathfrak{I}_x^\beta \mathfrak{I}_x^\beta \mathfrak{I}_y^\gamma u + 4\mathfrak{I}_x^\beta u \mathfrak{I}_x^\beta \mathfrak{I}_y^\gamma u + 2\mathfrak{I}_x^\beta \mathfrak{I}_x^\beta \mathfrak{I}_y^\gamma u = 0, \quad 0 < \alpha, \beta, \gamma \leq 1, \quad (1.1)$$

where $u = u(x, y, t)$ is a function of space variables x, y and temporal variable t , $\mathfrak{I}_t^\alpha u$, $\mathfrak{I}_x^\beta u$ and $\mathfrak{I}_y^\gamma u$ are conformable derivatives.

Various solutions of the classical CBS equation (at $\alpha = \beta = \gamma = 1$) were obtained by several methods, such as the Hirota bilinear method [17], the symmetry method [18], the multiple exp-function method [19], the improved (G'/G) -expansion method, the extended tanh methods [20, 21], the Sine-Gordon expansion method [22], the improved system technique [23] and so on.

The exp-function method [24] was applied to the fractional CBS equation with the modified Riemann-Liouville fractional derivative. The conformable fractional CBS equation was investigated by using (G'/G^2) -expansion method

[25] and $\tan(\phi(\xi)/2)$ -expansion method [26].

The rest of the paper is organized as follows. Some basic concepts of the conformable fractional derivative are mentioned in the next Section. In Section 3, details of the unified method and the modified Kudryashov method are given. Then in Section 4, we compare these two methods. The solutions of the space-time fractional $(2 + 1)$ -dimensional CBS equation obtained using these methods are presented in Section 5. We give some graphs of solution behavior in Section 6. Finally, a brief conclusion is provided in the last section.

2 Conformable fractional derivative

In this research, fractional derivatives are considered in the conformable sense. Let us present the definition and some properties of conformable fractional derivative [27, 28].

Definition 2.1. *If $f : (0, \infty) \rightarrow \mathbb{R}$, then the conformable fractional derivative of f of order α is defined as*

$$\mathfrak{I}_t^\alpha f(t) = \lim_{\varepsilon \rightarrow 0} \frac{f(t + \varepsilon t^{1-\alpha}) - f(t)}{\varepsilon}, \quad \forall t > 0, \quad 0 < \alpha \leq 1.$$

Some important properties of this derivative are given in the following theorem.

Theorem 2.2. *Suppose that $f(t)$ and $g(t)$ are α -conformable differentiable at a point $t > 0$, such that $\alpha \in (0, 1]$. Then*

1. $\mathfrak{I}_t^\alpha (af(t) + bg(t)) = a\mathfrak{I}_t^\alpha f(t) + b\mathfrak{I}_t^\alpha g(t), \quad \text{for all } a, b \in \mathbb{R}.$

2. $\mathfrak{I}_t^\alpha (t^\mu) = \mu t^{\mu-\alpha}, \quad \text{for all } \mu \in \mathbb{R}.$

3. $\mathfrak{I}_t^\alpha (f(t)g(t)) = g(t)\mathfrak{I}_t^\alpha (f(t)) + f(t)\mathfrak{I}_t^\alpha (g(t)).$

4. $\mathfrak{I}_t^\alpha \left(\frac{f(t)}{g(t)} \right) = \frac{g(t)\mathfrak{I}_t^\alpha (f(t)) - f(t)\mathfrak{I}_t^\alpha (g(t))}{g(t)^2}.$

5. $\mathfrak{I}_t^\alpha (f \circ g)(t) = t^{1-\alpha} g'(t) f'(g(t)),$

6. *In addition, if the function $f(t)$ is a differentiable function, then*

$$\mathfrak{I}_t^\alpha (f(t)) = t^{1-\alpha} \frac{df(t)}{dt}.$$

3 Description of two methods

In this section, we give descriptions of two promising and reliable methods: the unified method [11, 12, 13, 14] and the modified Kudryashov method [4, 5].

Consider a conformable nonlinear fractional partial differential equation in three independent variables x , y and t , as follows:

$$P(u, \mathfrak{I}_t^\alpha u, \mathfrak{I}_x^\beta u, \mathfrak{I}_y^\gamma u, \mathfrak{I}_{tt}^{2\alpha} u, \mathfrak{I}_{xx}^{2\beta} u, \mathfrak{I}_{yy}^{2\gamma} u, \dots) = 0, \quad 0 < \alpha, \beta, \gamma \leq 1, \quad (3.2)$$

where $u = u(x, y, t)$ is an unknown function, P is a polynomial of u and its derivatives. The first step is common for both methods. We seek traveling wave solutions of Eq.(3.2) by using a fractional complex transformation

$$u(x, y, t) = u(\eta), \quad \eta = p\frac{t^\alpha}{\alpha} + q\frac{x^\beta}{\beta} + r\frac{y^\gamma}{\gamma}, \quad (3.3)$$

where p , q and r are constants to be determined. Substituting this transformation into Eq.(3.2), we obtain the nonlinear ordinary differential equation of the form:

$$G(u, u', u'', \dots) = 0, \quad (3.4)$$

where $u' = \frac{du}{d\eta}$, $u'' = \frac{d^2u}{d\eta^2}$, ...

If possible, we should integrate Eq.(3.4) and, for simplicity, equate constants of integration to zero.

Below we provide a description of the unified method and the modified Kudryashov method.

3.1 The unified method

The main steps of the unified method are as follows:

Step 1. We suppose that the solution to Eq.(3.4) can be expressed in the form:

$$u(\eta) = A_0 + \sum_{i=1}^N (A_i \Theta^i(\eta) + B_i \Theta^{-i}(\eta)), \quad (3.5)$$

where A_i , B_i ($i = 0, 1, \dots, N$) are constants to be determined, N is a positive integer and $\Theta(\eta)$ satisfies the Riccati differential equation,

$$\Theta'(\eta) = \Theta^2(\eta) + \mu, \quad (3.6)$$

where $\Theta' = \frac{d\Theta}{d\eta}$ and μ is a real constant. Eq.(3.6) has the following exact solutions.

Family 1. If $\mu < 0$, then

$$\Theta(\eta) = \begin{cases} \frac{\pm\sqrt{-(A^2+B^2)\mu} - A\sqrt{-\mu} \cosh(2\sqrt{-\mu}(\eta+\eta_0))}{A \sinh(2\sqrt{-\mu}(\eta+\eta_0)) + B}, \\ \pm\sqrt{-\mu} + \frac{\mp 2A\sqrt{-\mu}}{A + \cosh(2\sqrt{-\mu}(\eta+\eta_0)) \mp \sinh(2\sqrt{-\mu}(\eta+\eta_0))}, \end{cases} \quad (3.7)$$

Family 2. If $\mu > 0$, then

$$\Theta(\eta) = \begin{cases} \frac{\pm\sqrt{(A^2-B^2)\mu} - A\sqrt{\mu} \cos(2\sqrt{\mu}(\eta+\eta_0))}{A \sin(2\sqrt{\mu}(\eta+\eta_0)) + B}, \\ \pm i\sqrt{\mu} + \frac{\mp 2Ai\sqrt{\mu}}{A + \cos(2\sqrt{\mu}(\eta+\eta_0)) \mp i \sin(2\sqrt{\mu}(\eta+\eta_0))}, \end{cases} \quad (3.8)$$

Family 3. If $\mu = 0$, then

$$\Theta(\eta) = -\frac{1}{\eta + \eta_0}, \quad (3.9)$$

where A , B and η_0 are real arbitrary constants.

Step 2. The positive integer N in Eq.(3.5) can be determined by balancing the highest order derivatives and the nonlinear terms in Eq.(3.4).

Step 3. Substituting Eq.(3.5) along with Eq.(3.6) into Eq.(3.4) and setting the coefficients of Θ^i ($i = 0, \pm 1, \pm 2, \dots$) to be zero, we get a system for A_i, B_i ($i = 0, 1, \dots, N$), p, q, r and μ .

Step 4. Assume that the system of algebraic equations in Step 3 is solved. Finally, we substitute the obtained constants together with the solution of Eq.(3.6) into (3.5) to obtain exact solutions of NFPDE Eq.(3.2), where η is given by (3.3).

3.2 The modified Kudryashov method

The following are the basic steps required to apply the modified Kudryashov method [4, 5].

Step 1. We suppose that the solutions of Eq.(3.4) can be expressed in powers of Q^i as,

$$u(\eta) = \sum_{i=0}^N a_i Q^i(\eta), \quad (3.10)$$

where a_i , ($i = 0, 1, \dots, N$) are unknowns to be calculated, and the function

$$Q(\eta) = \frac{1}{1 + da^\eta}, \quad (3.11)$$

is the solution of the nonlinear differential equation

$$Q'(\eta) = \ln(a) (Q^2(\eta) - Q(\eta)), \quad a \neq 0, 1. \quad (3.12)$$

Step 2. The positive integer N in Eq.(3.10) is determined by balancing higher order derivatives and nonlinear terms in Eq.(3.4).

Step 3. Substituting Eq.(3.10) along with Eq.(3.11) into Eq.(3.4) and equating the coefficients of each power of Q^i ($i = 0, 1, \dots, N$) to zero, we get a system of nonlinear equations for a_i ($i = 0, 1, \dots, N$), p , q and r .

Step 4. Then we solve this system of equations by using the Maple 18 package. Substituting the obtained values of the parameters in Eq.(3.10), we get exact solutions for Eq.(3.2).

4 Comparison of two methods

In this section, we will compare the two proposed methods.

Let us go back to Eq.(3.12); namely,

$$Q'(\eta) = \ln(a) (Q^2(\eta) - Q(\eta)),$$

We can rewrite it as follows

$$Q'(\eta) = \ln(a) \left(Q(\eta) - \frac{1}{2} \right)^2 - \frac{1}{4} \ln(a), \quad (4.13)$$

If we let $\psi(\eta) = Q(\eta) - \frac{1}{2}$, then

$$\psi'(\eta) = \ln(a) \psi^2(\eta) - \frac{1}{4} \ln(a). \quad (4.14)$$

Eq.(3.6), is a Riccati equation. It easy to see, that if $\mu = -\frac{(\ln(a))^2}{4}$ in

Eq.(3.6), then $\psi(\eta) = \frac{1}{\ln(a)} \Theta(\eta)$.

Since $\mu < 0$, the solutions of Eq.(3.6) have the form (3.7). Let us consider the last equation in the Family 1.

We have $\sqrt{-\mu} = \pm \frac{\ln(a)}{2}$. In both cases, the proof is similar. So we assume $\sqrt{-\mu} = \frac{\ln(a)}{2}$. Therefore,

$$\begin{aligned} \Theta(\eta) &= -\frac{\ln(a)}{2} + \frac{A \ln(a)}{A + \cosh(\ln(a)(\eta + \eta_0)) + \sinh(\ln(a)(\eta + \eta_0))}, \\ &= -\frac{\ln(a)}{2} + \frac{A \ln(a)}{A + e^{(\eta + \eta_0)\ln(a)}} = \ln(a) \left(-\frac{1}{2} + \frac{1}{1 + (e^{\eta_0 \ln(a)}/A) a^\eta} \right), \\ &= \ln(a) \left(-\frac{1}{2} + \frac{1}{1 + d a^\eta} \right) = \ln(a) \left(-\frac{1}{2} + Q(\eta) \right), \end{aligned}$$

where $d = e^{\eta_0 \ln(a)}/A$.

Then we compare the two forms of solutions

$$u(\eta) = \sum_{i=0}^N a_i (Q(\eta))^i = \sum_{i=0}^N a_i \left(\frac{1}{\ln(a)} \Theta(\eta) + \frac{1}{2} \right)^i = A_0 + \sum_{i=1}^N (A_i \Theta^i(\eta) + B_i \Theta^{-i}(\eta)).$$

Using the binomial expansion, we find connection between coefficients of the modified Kudryashov method and the unified method as follows:

$$A_i = \left(\frac{1}{\ln(a)} \right)^i \sum_{j=i}^N \left[\binom{j}{j-i} \left(\frac{1}{2} \right)^{j-i} a_j \right], \quad B_i = 0, \quad i = 0, 1, \dots, N.$$

Thus, we can conclude that the solutions obtained by the modified Kudryashov method can be transformed into some solutions obtained by the unified method, but the unified method gives more solutions. Through the above analysis, we get the following theorem.

Theorem 4.1. *The set of solutions obtained by the unified method includes the solutions obtained by the modified Kudryashov method.*

5 Implementation of methods

In this part, we obtain exact traveling wave solutions of the space-time fractional (2+1) dimensional Calogero-Bogoyavlenskii-Schiff equation (1.1). We use the transformation (3.3) to reduce Eq.(1.1) to the following nonlinear ordinary differential equation,

$$pqu'' + q^3ru^{(4)} + 6q^2ru''u' = 0, \tag{5.15}$$

Integrating Eq.(5.15) and equating the integration constants to zero, we get

$$pqu' + q^3ru''' + 3q^2r(u')^2 = 0. \tag{5.16}$$

5.1 The unified method

Balancing the highest order nonlinear term $(u')^2$ and the highest order derivative u''' , we have $N + 3 = 2N + 2$. So $N = 1$.

Thus, we seek the solution of Eq.(1.1) as

$$u(\eta) = A_0 + A_1\Theta(\eta) + B_1\Theta^{-1}(\eta). \tag{5.17}$$

Then, we substitute Eq.(5.17) into Eq.(5.16). Equating each coefficient of $\Theta^i (i = 0, \pm 1, \pm 2, \pm 3)$ to zero yields a system of algebraic equations for the unknowns A_0, A_1, B_1, p, q, r and μ . We find different sets of solutions of this system.

Result 1.

$$A_1 = -2q, \quad B_1 = 2q\mu, \quad p = 16q^2r\mu. \tag{5.18}$$

Result 2.

$$A_1 = -2q, \quad B_1 = 0, \quad p = 4q^2r\mu. \tag{5.19}$$

Result 3.

$$A_1 = 0, \quad B_1 = 2q\mu, \quad p = 4q^2r\mu. \tag{5.20}$$

Using these values, we construct the traveling wave solutions of Eq.(1.1) as follows,

$$\begin{aligned} u_{1,2}(x, y, t) &= A_0 - 2q \left(\frac{\pm\sqrt{-(A^2+B^2)\mu} - A\sqrt{-\mu} \cosh(2\sqrt{-\mu}(\eta+\eta_0))}{A \sinh(2\sqrt{-\mu}(\eta+\eta_0)) + B} \right) \\ &\quad + 2q\mu \left(\frac{\pm\sqrt{-(A^2+B^2)\mu} - A\sqrt{-\mu} \cosh(2\sqrt{-\mu}(\eta+\eta_0))}{A \sinh(2\sqrt{-\mu}(\eta+\eta_0)) + B} \right)^{-1}, \\ u_{3,4}(x, y, t) &= A_0 - 2q \left(\pm\sqrt{-\mu} + \frac{\mp 2A\sqrt{-\mu}}{A + \cosh(2\sqrt{-\mu}(\eta+\eta_0)) \mp \sinh(2\sqrt{-\mu}(\eta+\eta_0))} \right) \\ &\quad + 2q\mu \left(\pm\sqrt{-\mu} + \frac{\mp 2A\sqrt{-\mu}}{A + \cosh(2\sqrt{-\mu}(\eta+\eta_0)) \mp \sinh(2\sqrt{-\mu}(\eta+\eta_0))} \right)^{-1}, \end{aligned}$$

where $\eta = 16q^2r\mu \frac{t^\alpha}{\alpha} + q \frac{x^\beta}{\beta} + r \frac{y^\gamma}{\gamma}$, $\mu < 0$ and A, B and η_0 are real arbitrary constants.

$$\begin{aligned} u_{5,6}(x, y, t) &= A_0 - 2q \left(\frac{\pm\sqrt{(A^2-B^2)\mu} - A\sqrt{\mu} \cos(2\sqrt{\mu}(\eta+\eta_0))}{A \sin(2\sqrt{\mu}(\eta+\eta_0)) + B} \right) \\ &\quad + 2q\mu \left(\frac{\pm\sqrt{(A^2-B^2)\mu} - A\sqrt{\mu} \cos(2\sqrt{\mu}(\eta+\eta_0))}{A \sin(2\sqrt{\mu}(\eta+\eta_0)) + B} \right)^{-1}, \end{aligned}$$

$$u_{7,8}(x, y, t) = A_0 - 2q \left(\pm i\sqrt{\mu} + \frac{\mp 2Ai\sqrt{\mu}}{A + \cos(2\sqrt{\mu}(\eta + \eta_0)) \mp i \sin(2\sqrt{\mu}(\eta + \eta_0))} \right) + 2q\mu \left(\pm i\sqrt{\mu} + \frac{\mp 2Ai\sqrt{\mu}}{A + \cos(2\sqrt{\mu}(\eta + \eta_0)) \mp i \sin(2\sqrt{\mu}(\eta + \eta_0))} \right)^{-1},$$

where $\eta = 16q^2r\mu \frac{t^\alpha}{\alpha} + q \frac{x^\beta}{\beta} + r \frac{y^\gamma}{\gamma}$, $\mu > 0$ and A, B and η_0 are real arbitrary constants.

$$u_9(x, y, t) = A_0 + \frac{2q}{\eta + \eta_0},$$

where $\eta = 16q^2r\mu \frac{t^\alpha}{\alpha} + q \frac{x^\beta}{\beta} + r \frac{y^\gamma}{\gamma}$, $\mu = 0$ and η_0 are real arbitrary constants.

$$u_{10,11}(x, y, t) = A_0 - 2q \left(\frac{\pm \sqrt{-(A^2+B^2)\mu - A\sqrt{-\mu} \cosh(2\sqrt{-\mu}(\eta + \eta_0))}}{A \sinh(2\sqrt{-\mu}(\eta + \eta_0)) + B} \right),$$

$$u_{12,13}(x, y, t) = A_0 - 2q \left(\pm \sqrt{-\mu} + \frac{\mp 2A\sqrt{-\mu}}{A + \cosh(2\sqrt{-\mu}(\eta + \eta_0)) \mp \sinh(2\sqrt{-\mu}(\eta + \eta_0))} \right),$$

where $\eta = 4q^2r\mu \frac{t^\alpha}{\alpha} + q \frac{x^\beta}{\beta} + r \frac{y^\gamma}{\gamma}$, $\mu < 0$ and A, B and η_0 are real arbitrary constants.

$$u_{14,15}(x, y, t) = A_0 - 2q \left(\frac{\pm \sqrt{(A^2-B^2)\mu - A\sqrt{\mu} \cos(2\sqrt{\mu}(\eta + \eta_0))}}{A \sin(2\sqrt{\mu}(\eta + \eta_0)) + B} \right),$$

$$u_{16,17}(x, y, t) = A_0 - 2q \left(\pm i\sqrt{\mu} + \frac{\mp 2Ai\sqrt{\mu}}{A + \cos(2\sqrt{\mu}(\eta + \eta_0)) \mp i \sin(2\sqrt{\mu}(\eta + \eta_0))} \right),$$

where $\eta = 4q^2r\mu \frac{t^\alpha}{\alpha} + q \frac{x^\beta}{\beta} + r \frac{y^\gamma}{\gamma}$, $\mu > 0$ and A, B and η_0 are real arbitrary constants.

$$u_{18}(x, y, t) = A_0 + \frac{2q}{\eta + \eta_0},$$

where $\eta = 4q^2r\mu \frac{t^\alpha}{\alpha} + q \frac{x^\beta}{\beta} + r \frac{y^\gamma}{\gamma}$, $\mu = 0$ and η_0 are real arbitrary constants.

$$u_{19,20}(x, y, t) = A_0 + 2q\mu \left(\frac{\pm \sqrt{-(A^2+B^2)\mu - A\sqrt{-\mu} \cosh(2\sqrt{-\mu}(\eta + \eta_0))}}{A \sinh(2\sqrt{-\mu}(\eta + \eta_0)) + B} \right)^{-1},$$

$$u_{21,22}(x, y, t) = A_0 + 2q\mu \left(\pm \sqrt{-\mu} + \frac{\mp 2A\sqrt{-\mu}}{A + \cosh(2\sqrt{-\mu}(\eta + \eta_0)) \mp \sinh(2\sqrt{-\mu}(\eta + \eta_0))} \right)^{-1},$$

where $\eta = 4q^2r\mu \frac{t^\alpha}{\alpha} + q \frac{x^\beta}{\beta} + r \frac{y^\gamma}{\gamma}$, $\mu < 0$ and A, B and η_0 are real arbitrary constants.

$$u_{23,24}(x, y, t) = A_0 + 2q\mu \left(\frac{\pm\sqrt{(A^2-B^2)\mu} - A\sqrt{\mu} \cos(2\sqrt{\mu}(\eta+\eta_0))}{A \sin(2\sqrt{\mu}(\eta+\eta_0)) + B} \right)^{-1},$$

$$u_{25,26}(x, y, t) = A_0 + 2q\mu \left(\pm i\sqrt{\mu} + \frac{\mp 2Ai\sqrt{\mu}}{A + \cos(2\sqrt{\mu}(\eta+\eta_0)) \mp i \sin(2\sqrt{\mu}(\eta+\eta_0))} \right)^{-1},$$

where $\eta = 4q^2r\mu \frac{t^\alpha}{\alpha} + q \frac{x^\beta}{\beta} + r \frac{y^\gamma}{\gamma}$, $\mu > 0$ and A, B and η_0 are real arbitrary constants.

5.2 The modified Kudryashov method

According to the modified Kudryashov method, the solution (3.10) can be written as

$$u(\eta) = a_0 + a_1Q(\eta) \tag{5.21}$$

Substituting Eq.(5.21) into Eq.(5.16) and equating the coefficients of each power of Q^i ($i = 1, 2, 3, 4$) to zero, a system of algebraic equations is derived.

$$\begin{cases} Q^4 : 6q^3ra_1(\ln(a))^3 + 3q^2ra_1^2(\ln(a))^2 = 0, \\ Q^3 : -12q^3ra_1(\ln(a))^3 - 6q^2ra_1^2(\ln(a))^2 = 0, \\ Q^2 : pqa_1 \ln(a) + 7q^3ra_1(\ln(a))^3 + 3q^2ra_1^2(\ln(a))^2 = 0, \\ Q^1 : -pqa_1 \ln(a) - q^3ra_1(\ln(a))^3 = 0, \end{cases}$$

Solving this system, we get the following result:

$$a_1 = -2q \ln(a), \quad p = -q^2r (\ln(a))^2. \tag{5.22}$$

Using these values, we obtain the following exact solution

$$u^*(x, y, t) = a_0 - \frac{2q \ln(a)}{1 + da^\eta}, \tag{5.23}$$

where $\eta = -q^2r (\ln(a))^2 \frac{t^\alpha}{\alpha} + q \frac{x^\beta}{\beta} + r \frac{y^\gamma}{\gamma}$ and a_0, d are real arbitrary constants.

Remark 5.1. If we take $A_0 = a_0 - q \ln(a)$, $A = \frac{1}{d}$, $\sqrt{-\mu} = \frac{\ln(a)}{2}$, $\eta_0 = 0$, we get $u^*(x, y, t) = u_{13}(x, y, t)$.

6 Discussion

Various types of traveling waves solutions of Eq.(1.1) are obtained by using two considered methods. In this section, some graphical representations of

exact solutions with different parameter values are presented in Figure 1-4 to understand the behavior of solutions.

We consider two sets of fractional orders $\alpha = \beta = \gamma = 1$ and $\alpha = \beta = \gamma = 1/2$. Since some solutions $u(x, y, t)$ have real value only on a certain part on the domain, their graphs are not drawn on the entire domain. Figure 1 shows

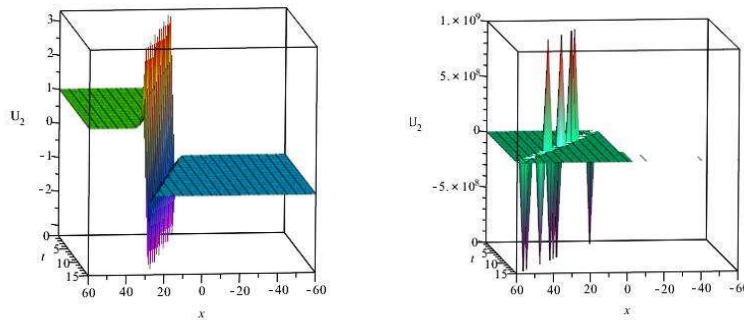

Figure 1: Plots of the solution $u_2(x, y, t)$ of Eq.(1.1) with $-60 \leq x \leq 60$, $0 \leq t \leq 15$ for (a) $\alpha = \beta = \gamma = 1$, (b) $\alpha = \beta = \gamma = 1/2$.

the solution $u_2(x, y, t)$ of Eq.(1.1) for values $q = \frac{1}{2}, r = 1, \mu = \frac{-1}{4}, A_0 = B = 0, A = 1, -60 \leq x \leq 60, 0 \leq t \leq 15$. This solution with $\alpha = \beta = \gamma = 1$, describing the solitary wave solution of singular kink type, is plotted in Figure 6. While Figure 6 demonstrates the singular multiple-soliton solution. Therefore, the fractional parameters α, β and γ affect the behavior of the solution by changing its type. The periodic traveling wave solution $u_5(x, y, t)$ with $\alpha = \beta = \gamma = 1$ is presented in Figure 6. Values of parameters are $q = \frac{1}{4}, r = -\frac{1}{2}, \mu = 3, A_0 = B = 0, A = 1$ and $-3\pi \leq x \leq 6\pi, 0 \leq t \leq 3\pi$. The graph, which is shown in Figure 6 and represents the multiple-soliton solution, corresponds to $u_5(x, y, t)$ with $\alpha = \beta = \gamma = 1/2$.

The solution u_{13} is expressed in terms of hyperbolic function and, accordingly, a kink solution is resulted as displayed in Figure 3. Figure 6 describes $u_{13}(x, y, t)$ with $\alpha = \beta = \gamma = 1$, while this solution with $\alpha = \beta = \gamma = 1/2$ is shown in Figure 6. Both cases are considered in the domain $-35 \leq x \leq 35, 0 \leq t \leq 20$ for $q = \frac{1}{2}, r = 4, \mu = \frac{-1}{4}, A_0 = B = 0$ and $A = 1$. Figure 3 shows that with a change in the values α, β, γ , the solution u_{13} exhibits the same physical behavior in both cases.

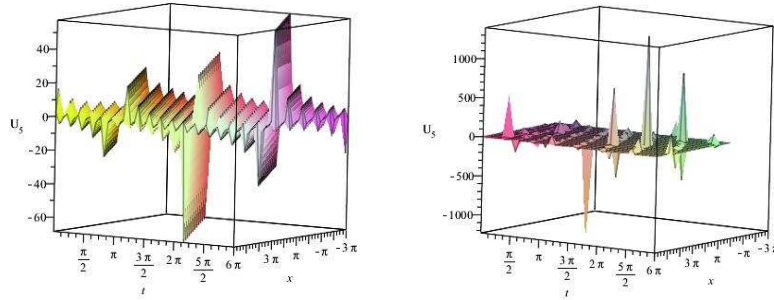

Figure 2: Plots of the solution $u_5(x, y, t)$ of Eq.(1.1) with $-3\pi \leq x \leq 6\pi$, $0 \leq t \leq 3\pi$ for (a) $\alpha = \beta = \gamma = 1$, (b) $\alpha = \beta = \gamma = 1/2$.

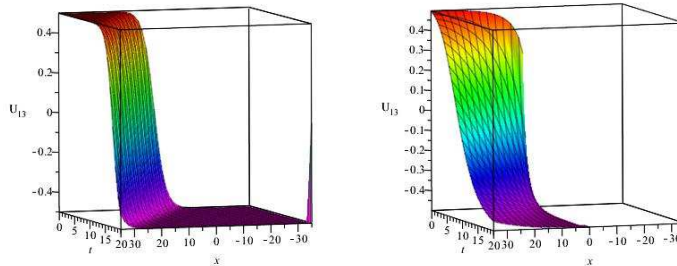

Figure 3: Plots of the solution $u_{13}(x, y, t)$ of Eq.(1.1) with $-35 \leq x \leq 35$, $0 \leq t \leq 20$ for (a) $\alpha = \beta = \gamma = 1$, (b) $\alpha = \beta = \gamma = 1/2$.

It should be mentioned that if we take $a = \exp(1)$, $d = 1$ and $a_0 = \frac{1}{2}$ in Eq.(5.23) then the solution $u^*(x, y, t)$ obtained by the modified Kudryashov method is similar to the solution u_{13} obtained by the unified method.

The graphs of the solution u_{24} are plotted for $-6\pi \leq x \leq 6\pi$, $0 \leq t \leq 3\pi$ and $q = \frac{1}{2}$, $r = 1$, $\mu = \frac{-1}{4}$, $A = 1$, $A_0 = B = 0$ and $A = 1$ in Figure 4. Figure 6 illustrates periodic solitary waves of the solution u_{24} with $\alpha = \beta = \gamma = 1$. The solution u_{24} with $\alpha = \beta = \gamma = 1/2$ gives the singular multiple-soliton solution. Its plot is shown in Figure 4(b).

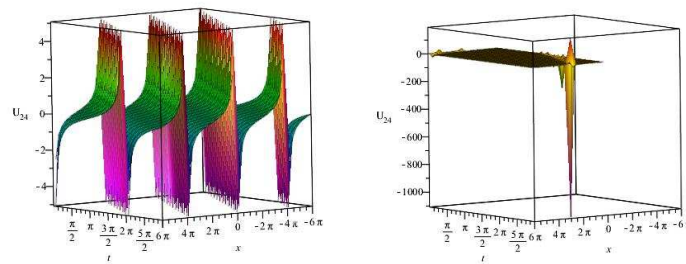

Figure 4: Plots of the solution $u_{24}(x, y, t)$ of Eq.(1.1) with $-6\pi \leq x \leq 6\pi$, $0 \leq t \leq 3\pi$ for (a) $\alpha = \beta = \gamma = 1$, (b) $\alpha = \beta = \gamma = 1/2$.

7 Conclusion

In this paper, we presented and compared the unified method and the modified Kudryashov method. The connection between them was established. Thus, we have shown that all solutions obtained by the modified Kudryashov method can be transformed into solutions obtained by the unified method. Then we applied the considered methods to construct exact traveling wave solutions for the nonlinear conformable (2+1)-dimensional Calogero-Bogoyavlenskii-Schiff equation. Various solutions were derived, such as one-soliton, kink, anti-kink, periodic wave solutions, solitary wave solutions and multiple-soliton solutions. Some solutions were presented graphically to understand their behavior. Comparing our solutions with the exact solutions obtained in [25], in which the authors employed the (G'/G^2) -expansion method, we can observe that some of the solutions are new. It is worth mentioning that at $\alpha = \beta = \gamma = 1$, the classical CBS equation is recovered, which shows that the presented methods yield some of the exact solutions obtained in [20]. These two methods can also be effectively applied to a wide range of nonlinear fractional partial differential equations.

References

- [1] H. Khan, S. Barak, P. Kumam, M. Arif, Analytical Solutions of Fractional Klein-Gordon and Gas Dynamics Equations, via the (G'/G) -Expansion Method, *Symmetry*, **11**, (2019), 566.
- [2] O. Guner, A. Bekir, K. Hosseini, Solitary wave solutions of nonlinear conformable time-fractional Boussinesq equations, *Acta Physica Polonica A*, **136**, no. 1, (2019), 135.
- [3] R. Nuruddeen, A. M. Nass, Exact solitary wave solution for the fractional and classical Gew-Burgers equations: an application of Kudryashov method, *Journal of Taibah University for Science*, **12**, (2018), 309–314.
- [4] D. Kumar, A. R. Seadawy, A. K. Joardar, Modified Kudryashov method via new exact solutions for some conformable fractional differential equations arising in mathematical biology, *Chinese journal of physics*, **56**, no. 1, (2018), 75–85.
- [5] H. M. Srivastava, D. Baleanu, J. A. T. Machado, M. S. Osman, H. Reza-zadeh, S. Arshed, H. Gnerhan, *Traveling wave solutions to nonlinear directional couplers by modified Kudryashov method*, *Physica Scripta*, **95**, no. 7, (2020), 075217.
- [6] O. Guner, A. Bekir, The Exp-function method for solving nonlinear space-time fractional differential equations in mathematical physics, *Journal of the Association of Arab Universities for Basic and Applied Sciences*,. **24**, (2017), 277–282.
- [7] S. Bibi, S. T. Mohyud-Din, U. Khan, N. Ahmed, Khater method for nonlinear Sharma-Tasso-Olver (STO) equation of fractional order, *Results in physics*, **7**, (2017), 4440–4450.
- [8] M. Eslami, F. S. Khodadad, F. Nazari, H. Rezazadeh, The first integral method applied to the Bogoyavlenskii equations by means of conformable fractional derivative, *Opt. Quantum Electron.*, **49**, (2017), 1–18.
- [9] Y. Pandir, A. Yildirim. Analytical approach for the fractional differential equations by using the extended tanh method, *Waves in Random and Complex Media*, **28**, (2018), 399–410.

- [10] K. Ali , R. Nuruddeen, Analytical treatment for the conformable space-time fractional Benney-Luke equation via two reliable methods, International Journal of Physical Research, **5**, (2017), 109–114
- [11] . F. Gzkzl, . Akal, T. Aydemir, Unification of all hyperbolic tangent function methods, Open Physics, **14**, (2016), 524–541.
- [12] S. Akcagil, T. Aydemir, A new application of the unified method, New Trends Math. Sci., **6**, (2018), 185–199.
- [13] M. Alquran, A. Dagher, M. Al-Dolat, Exact traveling wave solutions for the celebrated gardner model and the nonlinear Klein-Gordon system by means of the celebrated unified method, International Journal of Applied and Computational Mathematics, **5**, (2019), 78.
- [14] S. Akcagil, Solitary type solutions for the long-short-wave interaction system using the unified method, Bitlis Eren Universitesi Fen Bilimleri Dergisi, **7**, (2018), 133–143.
- [15] OI. Bogoyavlenskii, Breaking solitons, III, Math USSR-Izvestiya. **36**, (1991), 129–137.
- [16] J. Schiff, Integrability of Chern-Simons-Higgs vortex equations and a reduction of the self-dual Yang-Mills equations to three dimensions, In Painlevé Transcendents. Springer, MA. Boston, (1992), 393–405.
- [17] A. M. Wazwaz, The (2+1) and (3+1)-dimensional CBS equations: multiple soliton solutions and multiple singular soliton solutions, Z. Naturforsch, **65**, (2010), 173–181.
- [18] G. M. Moatimid, R. M. El-Shiekh, A. G. A. Al-Nowehy, Exact solutions for Calogero-Bogoyavlenskii-Schiff equation using symmetry method, Applied Mathematics and Computation, **220**, (2013), 455–462.
- [19] M. E. Elsayed Zayed, Abdul-Ghani Al-Nowehy, The Multiple Exp-Function Method and the Linear Superposition Principle for Solving the (2+1)-Dimensional CalogeroBogoyavlenskii Schiff Equation, Z. Naturforsch, **70**, (2015), 775–779.
- [20] M. Shakeel, S. T. Mohyud-Din, Improved(G'/G)-expansion and extended tanh methods for (2 +1)-dimensional Calogero-Bogoyavlenskii-Schiff equation, Alexandria Engineering Journal, **54**, (2015), 27–33.

- [21] S. M. Mabrouk, Traveling Wave Solutions of the Extended Calogero-Bogoyavlenskii-Schiff Equation, *International Journal of Engineering Research & Technology*, **8**, (2019), 577–580.
- [22] H. M. Baskonus, T. A. Sulaiman, H. Bulut, New solitary wave solutions to the (2+1)-dimensional CalogeroBogoyavlenskiiSchiff and the Kadomtsev-Petviashvili hierarchy equations, *Indian Journal of Physics*, **91**, (2017), 1237–1243.
- [23] J. H. Choi, H. Kim, R. Sakthivel, Periodic and solitary wave solutions of some important physical models with variable coefficients, *Waves in Random and Complex Media*, (2019), 1–20.
- [24] K. Ayub, M. Y. Khan, Mahmood Ul-Hassan, Solitary and periodic wave solutions of CalogeroBogoyavlenskiiSchiff equation via exp-function methods, *Computers & mathematics with applications*. **74**, (2017), 3231-3241.
- [25] H. C. Yaslan, A. Girgin, New exact solutions for the conformable space-time fractional KdV, CDG,(2+ 1)-dimensional CBS and (2+ 1)-dimensional AKNS equations, *Journal of Taibah University for Science*, **13**, (2019), 1–8.
- [26] Z. Hammouch, T. Mekkaoui, P. Agarwal, Optical solitons for the Calogero–Bogoyavlenskii–Schiff equation in (2+1) dimensions with time-fractional conformable derivative, *The European Physical Journal Plus*, **133**, (2018), 248.
- [27] R. Khalil, M. Al Horani, A. Yousef, M. Sababheh, A new definition of fractional derivative, *Journal of Computational and Applied Mathematics*, **264**, (2014), 65–70.
- [28] T. Abdeljawad, On conformable fractional calculus, *Journal of computational and Applied Mathematics*, **279**, (2015), 57–66.