

Direction of Arrival and Least Square Error Technique used in Massive MIMO for Channel Estimation

Asif Ali¹, Maurizio Magarini², Nasrullah Pirzada³,
Muhammad Aamir Panhwar⁴, Aqeel Ahmed⁵

^{1,5}Institute of Information Communication Technology
Mehran University of Engineering and Technology
Jamshoro, Pakistan

²Department of Electronics, Information and Bioengineering
Politecnico de-Milano
1863 Milan, Italy

³Department of Telecommunication Engineering
Mehran University of Engineering and Technology
Jamshoro, Pakistan

⁴Department of Biomedical Engineering
Mehran University of Engineering and Technology
Jamshoro, Pakistan

email: asifbhoot36@gmail.com, amir.panhwar@faculty.muet.edu.pk

(Received October 8, 2020, Accepted November 18, 2020)

Abstract

Massive multiple-input multiple-output (MIMO) technology is one of the prominent candidate for next generation wireless communication networks; i.e., 5G. Massive MIMO systems are integrated with the array antenna technology to enhance the performance of future networks. This paper investigates two channel estimation methods,

Key words and phrases: Massive MIMO, Wireless communication, channel estimation, DOA, LSE, Beam-forming, MUSIC Algorithm.

AMS (MOS) Subject Classifications: 93E24, 47A11.

ISSN 1814-0432, 2021, <http://ijmcs.future-in-tech.net>

namely the least square error (LSE) and the multiple signal classification (MUSIC) algorithm for direction of arrival (DoA). A mathematical model is designed for the channel estimation using both techniques (LSE and MUSIC). Moreover, the performance of these techniques is compared for different parameters such as number of array elements, number of snapshots, transmitter array response pattern and signal to noise ratio (SNR). The impact of SNR on bit error rate (BER) performance is analyzed. By varying these elements, we found that there is a significant change in the accuracy and resolution of MUSIC algorithm for DOA estimation.

1 Introduction

Massive multiple-input multiple-output (MIMO) systems have emerged as a potential technology for the development and the deployment of next generation wireless communication systems [1]. As shown in Fig.1, a massive MIMO system consists of a large number of array antennas which are equipped with base station (BS) and consistently serve a huge number of users [2]. Keeping in the same resource block of time-frequency, facilitating substantial gains in the energy efficiency and the capacity. Therefore, with the huge number of antenna elements the BS can execute a large number of user beam-forming with considerable narrower beam width so that it can serve the significant amount of users with smaller interference among them. In addition, a large number of antenna arrays provide larger gains [3]. Under favorable conditions, the channel vectors for the different users are considered orthogonal as increased in the antennas as the BS tends to infinity [4]. As a result, the simple signal detection and filtering techniques, for instance matched filtering (MF), can be operated to quash the multi-user interference under the knowledge of accurate assumption of the channels [5]. Practically, the availability of the perfect channel state information is not possible.

In Massive MIMO multi-cell systems pilot signaling in terms of training sequences is used to acquire CSI within the coherence time [6], [7]. Therefore, the number of users is equal to the number of training sequences. Assuming the number of orthogonal pilot sequences are limited compared to channel coherence time interval, the same training sequence can be reused in the neighboring cells. The interference between the pilot sequences of the neighboring cells is also recognized as the pilot contamination effect. It facilitates the poor channel approximations [8] and considerably affects the achievable data rates of massive MIMO systems that depend on the linear signal process-

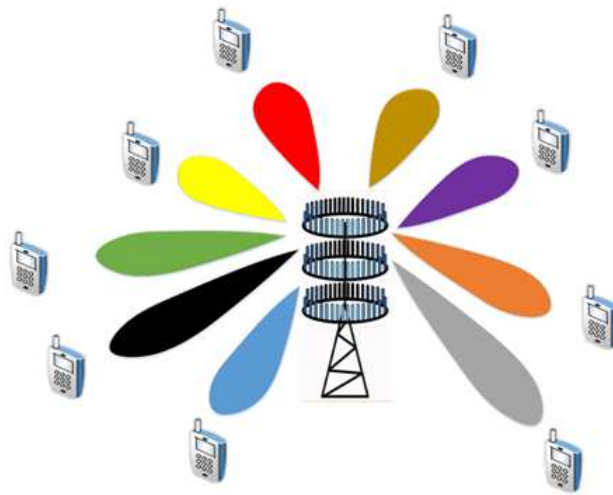

Figure 1: Block diagram of Massive MIMO communication

ing [9]. MIMO wireless communication systems tolerate a dramatic increase in channel capacity by adding the dimension of conventional time and frequency. This is done through the sampling space [10] with a huge number of antenna elements, establishing the antenna arrays at both sides of the transmitter and the receiver. Millimeter wave has recently seemed as a feasible solution for the 5th generation wireless communication systems (5G) [11].

Definitely, smaller wavelength permits us to densify the half wavelength through the antenna resulting in higher angular resolution [12] and capacity. The channel estimation of the receiver signal can be done through the MUSIC algorithm to find the direction of arrival signal [13], [14]. This method helps to estimate the noise from the available subspace sample. This observation shows the growth of the massive MIMO field; i.e., the systems study up to hundreds or even thousands of antennas. In mobile communication systems, information is transmitted through changing the phase or amplitudes of the radio waves. The performance of the receiver is highly dependent on the accuracy of the estimated instant channel since this causes the degradation in the quality of system. Channel state information (CSI) provides the known channel properties of the wireless communication link [15], [16] and the detailed knowledge of signal propagation between transmitter and the receiver and tells about the effects of scattering and fading [17]. The CSI can integrate current channel conditions with transmission data for achieving reliable

communication link with high data rates. This CSI should be estimated at the receiver side and fed back to the transmitter side.

This paper is further divided as follows: sections 2 and 3 discuss the DOA estimation and the least square error estimation. Moreover, in section 4 the simulation model is discussed. Furthermore, section 5 analyzes the results and discussion. Finally, section 6 provides a conclusion.

2 DOA and LSE Estimations

In the direction of arrival estimation, the MUSIC algorithm DOA estimation method was investigated. The array output x can be achieved by its covariance matrix R_x from equation (2.1) and the autocorrelation of the received signal.

$$R_x = AR_sA^H + R_N \quad (2.1)$$

Autocorrelation of the received signal with covariance matrix

$$P_{music}(\theta) = \frac{1}{(a^H(\theta)E_nE_n^Ha(\theta))} \quad (2.2)$$

The spectrum function from equation (2.2) is calculated to obtain the approximate value of the direction of arrival. The denominator of the formula is the product of a signal vector and noise matrix, where $a(\theta)$ is orthogonal with each column of E_n . In this model, θ varies to estimate the arrival angle by finding the peaks of the signal. The spectrum function is calculated and then the estimated value of direction of arrival (DOA) is obtained by penetrating the peaks. The least square error estimation is useful when the channel and the noise distribution are unknown. The *LS* estimator known as minimum variance unbiased estimator as given in equation (2.3). H represents the least square estimate of the coefficient vector as given in the equation (2.4) and X represents the diagonal matrix.

$$H = (X^HX)^{-1}YX^H \quad (2.3)$$

$$H = X^{-1}Y \quad (2.4)$$

3 Simulation Model

This section discusses the block diagram of massive MIMO for channel estimation. The block diagram, Fig. 2, shows the working process of massive

MIMO channel estimation system. The transmitter part presents the QAM modulation with pilot sequences and the communication MIMO channel with AWGN noise while at the receiver end we use the DOA estimation and channel estimation is used with QAM demodulation.

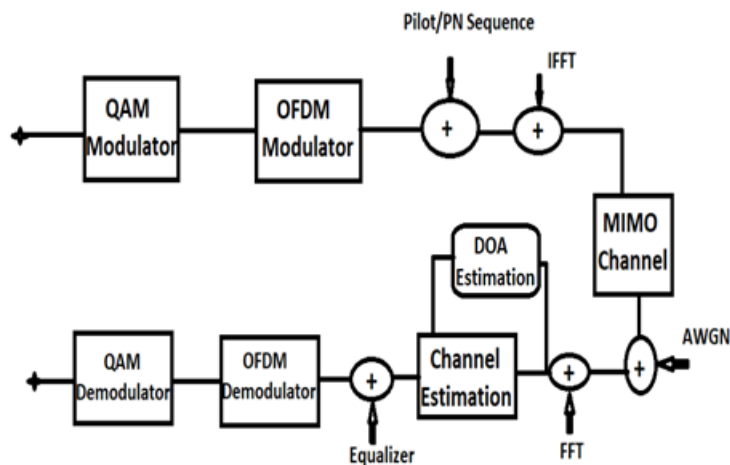

Figure 2: Block diagram of Massive MIMO for channel estimation

4 Results and discussion

This section presents the results and discussion of simulation conducted through MATLAB software. The design system (model of Massive MIMO with channel state information) is analyzed at the transmitter and receiver end by using the least square channel estimation techniques and for the DOA estimation used with the MUSIC algorithm. Moreover, the analysis and detailed discussion show in the graphs of BER vs SNR. Furthermore, the graph in which the number of bits in error are showing is analyzed through the constellation plot with QAM modulation.

Fig.3 shows the effect of increasing the number of array elements on the performance of the massive MIMO based on the MUSIC algorithm. Note that two narrow band signals with different incident angles (20 and 60) are plotted which are not correlated with the ideal white Gaussian noise used

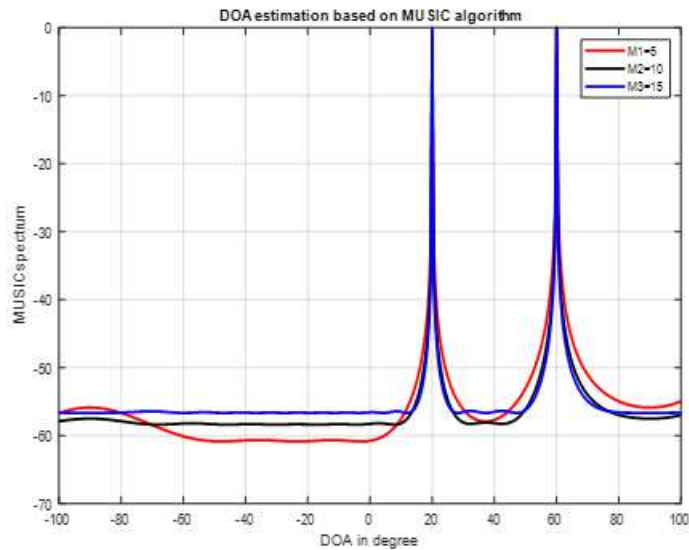

Figure 3: The simulation results of MUSIC algorithms and the number of array elements

with the SNR value of 20dB. The number of array elements is 5, 10 and 15. The element spacing is kept as half of the input signals wavelength. The number of snapshots is almost 200. By increasing the number of array elements, the direction of arrival (DOA) estimation spectral beam width becomes narrower and the system is more directive and the ability of the spatial signal is improved. In addition, more accurate direction of arrival (DOA) estimation can be achieved by increasing the number of array elements. However, one of the drawbacks is that the more number of array elements needed the more data processing and more amount of computation which decreases the system speed as well. From Fig.3, note that the number of array elements amounts in M2 and M3 from their beam width both are almost similar. In practice, the number of array elements can be selected according to their specific conditions which assures accuracy according to the estimated spectrum. This value should also be considered important to compensate the waste of resources and to improve the speed of the system and increase the efficiency.

We can infer the impact of the number of samples on performance and the computation power of DOA estimation method. By keeping other conditions

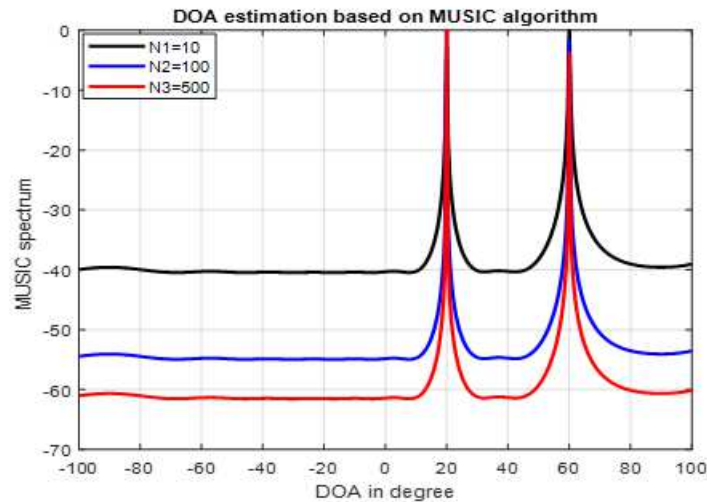

Figure 4: The simulation results of MUSIC algorithms and the number of snapshots

the same, except the snapshots, the accuracy of DOA increases but at the cost of additional processing power of the system. From the Fig.4, note that DOA estimation spectrum becomes narrower and the accuracy of the MUSIC algorithms is improved. In practice, the reasonable sampling snapshots will ensure the accuracy of DOA estimation to reduce the amount of computation and improve the speed and efficiency. Fig.5 shows the impact of varying the SNR values. Note that increasing the value of SNR, performance of the MUSIC algorithm is improved. However, performance degrades at low SNR values. The beam width of DOA estimation spectrum becomes narrow, the direction of arrival signal becomes clearer and improves the accuracy of MUSIC algorithm. The value of SNR can directly affect the performance of high resolution DOA estimation algorithm. At the low SNR values the performance of MUSIC algorithms decline sharply. Thus to improve the estimation performance under the low SNR remains a hot topic of research. Fig. 6 shows the transmitter array response of massive MIMO. Note that the receiver is exactly in the direction of main beam which means that the beam focuses the receiver signal so that the receiver gets maximum energy all the time. It will improve the receiver performance in terms of link capacity,

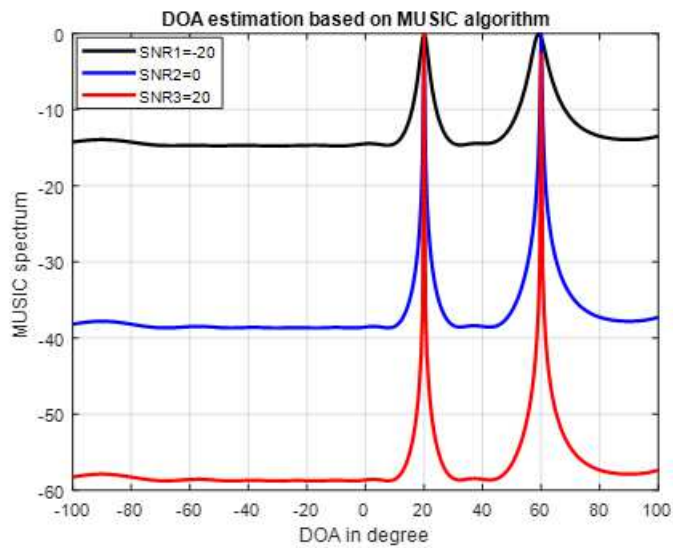

Figure 5: The simulation results of MUSIC algorithms with different value of SNR

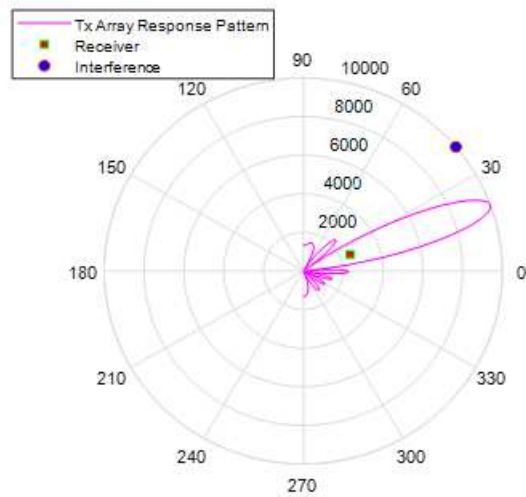

Figure 6: Transmitter array response pattern of the beamforming at 20 degree

energy efficiency and spectral efficiency. In addition, beam-forming creates the deep nulls in the direction of interference so that resources are not wasted. The constellation plots of the 16-QAM is shown in the Fig.7 which summaries the bits which are in error. However, we are transmitting the higher number of bits from the transmitter almost 1290240 bits. In these bits, the error ratio is almost negligible as 0.02% of the total bits are in error. The exact number of the bits in error is 573.

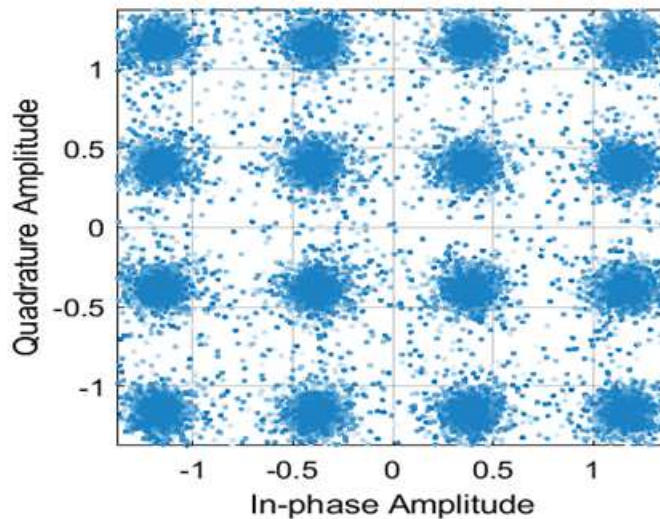

Figure 7: Constellation plot shows the number of bits in error

5 Conclusion

The main focus of this paper was channel and direction of arrival estimations which were performed through least square error and MUSIC algorithm. By increasing the number of array elements, the number of snapshots and incident angles of the MUSIC algorithm provided a higher resolution. When the number of array element was greater than half of the wavelength, the spatial spectrum created the false peaks in other direction except signal source direction. By using low SNR, a smaller difference in the incident angles was observed and the performance of the MUSIC algorithm declined. Initially, it was estimated that the direction of arrival through MUSIC implementation

at certain angle to steer the main beam in the direction of user to get maximum energy all the times. However, it was observed that the receiver got some extra energy and the performance of the receiver improved in terms of high data rate, spectral efficiency, energy efficiency and link reliability.

References

- [1] F. Rusek et al., Scaling up MIMO: Opportunities and challenges with very large arrays, *IEEE Signal Process. Mag.*, **30**, no. 1, (2013), 40–60.
- [2] A. Ali, I. A. Qureshi, A. L. Memon, S. A. Memon, E. Saba, Spectral Efficiency of Massive MIMO Communication Systems with Zero Forcing and Maximum Ratio Beamforming, *Int. J. Adv. Comput. Sci. Appl.*, **9**, no. 12, (2018), 383–388.
- [3] E. Bjrnsen, L. Van Der Perre, S. Buzzi, E. G. Larsson, Massive MIMO in Sub-6 GHz and mmWave: Physical , Practical and Use-Case Differences, *IEEE Wireless Commun.*, **26**, no. 2, (2019), 100–108.
- [4] E. Ali, M. Ismail, R. Nordin, N. F. Abdulah, Beam-forming techniques for massive MIMO systems in 5G: overview, classification , and trends for future research, *Front. Inf. Tech. Electron. Eng.*, **18**, no. 6, (2017), 753–772.
- [5] Z. Lv, Y. Li, A Channel State Information Feedback Algorithm for Massive MIMO Systems, *IEEE Commun. Lett.*, **20**, no. 7, (2016), 1461–1464.
- [6] G. Sklivanitis, K. Tountas, D. A. Pados, S. N. Batalama, Small-sample-support Channel Estimation for Massive MIMO systems in *IEEE International conference on acoustics, speech and signal processing*, , nos. 15-20, (2018), 1–5.
- [7] T. E. Bogale, L. B. Le, Pilot optimization and channel estimation for multiuser massive MIMO systems, *48th Annu. Conf. Inf. Sci. Syst.*, (2014), 1–6.
- [8] T. L. Marzetta, Noncooperative Cellular Wireless with Unlimited Numbers of Base Station Antennas, *IEEE Trans. Wireless Commun.*, **9**, no. 11, (2010), 3590–3600.

- [9] G. Erik, L. Thomas, Massive MIMO for Next Generation Wireless Systems, *IEEE Commun. Mag.*, **52**, no. 2, (2016), 186–195.
- [10] O. A. Saraereh, I. Khan, Q. Alsafasfeh, S. Alemaishat, S. Kim, Low-Complexity Channel Estimation in 5G Massive MIMO-OFDM Systems, *MDPI sensors*, no. 11, (2019), 1–17.
- [11] A. F. G. Theodore, S. Rappaport, Shu Sun et al., Millimeter Wave Mobile Communications for 5G Cellular: It Will Work!, *IEEE Access*, **1**, no. 2, (2013), 335–349.
- [12] A. L. Swindlehurst, E. Ayanoglu, P. Heydari, F. Capolino, Millimeter-Wave Massive MIMO: The Next Wireless Revolution, *IEEE Commun. Mag.*, (2014), 56–62.
- [13] P. P. Likhitkar, C. N. Deshmukh, Beam-forming for MIMO-OFDM Wireless Systems, *Eur. J. Adv. Eng. Tech.*, **2**, no. 6, (2015), 14–19.
- [14] F. Wen, C. Liang, Improved tensor-MODE based direction-of-arrival estimation for massive MIMO systems, *IEEE Commun. Lett.*, **19**, no. 12, (2015), 2182–2185.
- [15] J. Liu, S. Member, A. Eryilmaz, S. Member, N. B. Shroff, E. S. Bentley, Understanding the Impacts of Limited Channel State Information on Massive MIMO Cellular Network Optimization, *IEEE J. Sel. Areas Commun.*, **35**, no. 8, (2017), 1715–1727.
- [16] O. Nyr et al., Channel State Information Feedback Overhead Reduction Using Arithmetic Coding In Massive MIMO systems, *3rd Int. Conf. Signal Process. Integr. Networks*, (2016), 328–331.
- [17] A. Almamori, Estimation of Channel State Information for Massive MIMO Based on Received Data Using Kalman Filter, *IEEE 8th Annual Comput. Commun. Work. Conf.*, (2018), 665–669.